

FRONT VIEW

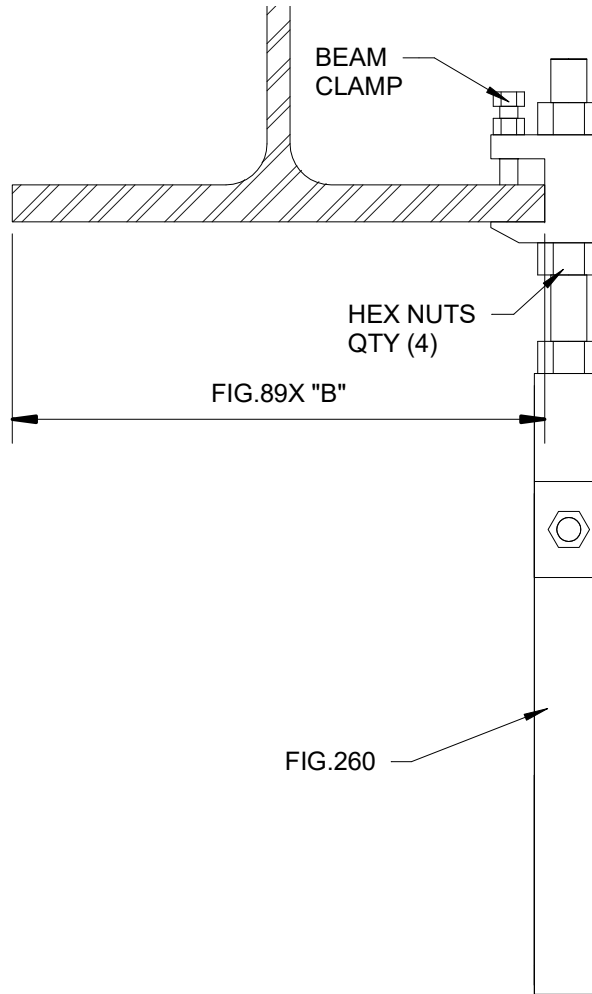

SIDE VIEW

FIG.260 ADJ. CLEVIS:

<input type="checkbox"/> 1/2"ø	<input type="checkbox"/> 3"ø
<input type="checkbox"/> 3/4"ø	<input type="checkbox"/> 3 1/2"ø
<input type="checkbox"/> 1"ø	<input type="checkbox"/> 4"ø
<input type="checkbox"/> 1 1/4"ø	<input type="checkbox"/> 5"ø
<input type="checkbox"/> 1 1/2"ø	<input type="checkbox"/> 6"ø
<input type="checkbox"/> 2"ø	<input type="checkbox"/> 8"ø
<input type="checkbox"/> 2 1/2"ø	

FIG.146 ATR:

A= \_\_\_\_\_

<input type="checkbox"/> 3/8"	<input type="checkbox"/> 1/2"
<input type="checkbox"/> 5/8"	<input type="checkbox"/> 3/4"

BEAM CLAMP:

<input type="checkbox"/> FIG.92	<input type="checkbox"/> 3/8"	<input type="checkbox"/> 1/2"
<input type="checkbox"/> FIG.93	<input type="checkbox"/> 3/8"	<input type="checkbox"/> 1/2"
<input type="checkbox"/> FIG.94	<input type="checkbox"/> 5/8"	<input type="checkbox"/> 3/4"

FINISH:

<input type="checkbox"/> PLAIN
<input type="checkbox"/> HOT-DIPPED GALV.
<input type="checkbox"/> ELECTROPLATED GALV.



CONTRACTOR:	PROJECT NAME:	DESCRIPTION: FIG.260 CLEVIS ASSEMBLY	CHECKED BY:	CONTRACT NO.:
DATE:	REV:		DRAWN BY:	SHEET NO.:
				CLEVIS-